

SIGMA

SIGMA

sigma-global.com

CINE LENS

CINE LENS

SIGMA

Cine lens

Revolutionary lenses for the era of high resolution digital cinematography

In the new era of high-resolution movie production, the arrival of reasonably priced, high-performance digital cinema cameras has changed the standard of what makes an excellent product in the industry and has expanded the freedom and potential of movie production. At the same time, when it comes to cine lenses, price and brand recognition are still often taken as proof of performance, which ends up being proportional to the production budget. In contrast to consumer products, professional cinema equipment is by its nature difficult to manufacture in volume, in turn causing lens R&D and innovations in manufacturing technology to lag behind progress in cameras. But SIGMA is different. Responding to the demanding requirements for lenses in the era of ultra-high-megapixel still photography, SIGMA has developed the technologies required to produce high-performance

lenses in volume. They have what it takes to offer a new solution to the cine lens market. At SIGMA's sole production site, the Aizu factory, they perform nearly all processes in house, from parts and mold production to final lens assembly. This vertically integrated production system comprises both product development and manufacturing, making it a true one-stop resource. Their artisans bring expertise and skill together at the highest level in the pursuit of outstanding optical performance, while their suite of leading-edge manufacturing technologies make possible ultra-efficient, highly precise volume production. Offering a full lineup that delivers compact design and maximum optical performance at minimal cost. A lineup that satisfies every professional film making need while expanding the freedom and potential of cinematography. A lineup that leverages minimal equipment and investment to maximum results. With the goal of providing uniquely innovative lenses and unprecedented value, SIGMA has developed its new line of cine lenses.

100

percent retained

&

100

percent new



100% retained

SIGMA has combined the highest level of optical performance with compact design while keeping the cost of development and production to a minimum. SIGMA had played the role of leader in the current era of 50-megapixel-plus ultra-high-resolution still photography. Now, in the realm of cine lenses, SIGMA is leveraging the outstanding optical performance of its Global Vision still lens lineup, which has been acclaimed by photographers around the world. Featuring the same high-quality optical components including lens cells and aperture mechanisms, these cine lenses deliver the highest level of optical performance and amazing value.



100% new

While retaining the same superb optical system, SIGMA's cine lenses feature a completely updated mechanical structure. Supported by this new design, the optimized specification includes all of the essential functions required for modern cinematography. Since its foundation SIGMA has believed in achieving top performance via high-precision parts. This principle and SIGMA's leading-edge manufacturing technologies have made possible ultra-high-efficiency mass production of these new lens lines.

Solutions for movie production.
Innovations for creative expression.



FRONT
DIAMETER
95 mm

FILTER
DIAMETER
82 mm

IMAGE
DIAMETER
28.4 mm

18

35

T2.0

SIGMA



RED
DRAGON

DSLR

• 1/4 •

M3

M3

Zoom Lenses

For outstanding T2 brightness throughout the zoom range, SIGMA's High Speed Zoom Line offers an 18-35mm T2 lens and a 50-100mm T2 lens. The FF Zoom Line offers full-frame (FF) coverage with a 24-35mm T2.2 FF lens. Optimized for ultra-high-resolution cinematography, every lens in these two lines is ready for 6K-8K shooting.

In addition, these innovative cine lenses combine two valuable qualities rarely found together: outstanding image quality and amazing compactness.



18-35mm T2

Diameter: Actual size



50-100mm T2



24-35mm T2.2 FF

Diameter: Actual size

Zoom lens specifications



High Speed Zoom Line		18-35mm T2	50-100mm T2
Focal Length		18-35mm	50-100mm
Aperture(T)		T2 to T16	T2 to T16
Number of Diaphragm Blades		9 (Rounded diaphragm)	9 (Rounded diaphragm)
Close Focus ¹		0.28m / 11"	0.95m / 3'2"
Image Coverage		S35 Digital Φ 28.4mm	S35 Digital Φ 28.4mm
Front diameter		95mm	95mm
Filter Size		82mm	82mm
Length			
	EF mount ²	129.5mm	175.2mm
	E-mount ³	155.5mm	201.2mm
	PL mount ⁴	121.5mm	167.2mm
Weight ⁵			
	EF mount	1445g	1885g
	E-mount	1505g	1945g
	PL mount	1410g	1830g
FF ⁶		-	-
S35 ⁷		68.7°–38.7°	27.6°–14.0°
APS-C ⁸		66.7°–37.4°	26.7°–13.5°
Barcode No.			
	EF mount	0085126 210663	0085126 693664
	E-mount	0085126 210670	0085126 693671
	PL mount	0085126 210687	0085126 693688

¹ Close focus distance is measured from the image plane ² Front to EF mount flange ³ Front to E-mount flange ⁴ Front to PL mount flange ⁵ Without lens support foot ⁶ Horizontal angle of view for a full-frame camera aperture (aspect ratio 1:1.5, dimensions 36mm×24mm / 1.42"× 0.94") ⁷ Horizontal angle of view for a super 35 digital cinema camera aperture (aspect ratio 1:1.8, dimensions 24.6mm×13.8mm / 0.97"× 0.54") ⁸ Horizontal angle of view for an APS-C camera aperture (aspect ratio 1:1.5, dimensions 23.7mm×15.7mm / 0.93"× 0.62") The specifications are subject to change without a notice.

FF Zoom Line		24-35mm T2.2 FF
Focal Length		24-35mm
Aperture(T)		T2.2 to T16
Number of Diaphragm Blades		9 (Rounded diaphragm)
Close Focus ¹		0.28m / 11"
Image Coverage		FF Φ 43.3mm
Front diameter		95mm
Filter Size		82mm
Length		
	EF mount ²	122.7mm
	E-mount ³	148.7mm
	PL mount ⁴	-
Weight ⁵		
	EF mount	1440g
	E-mount	1500g
	PL mount	-
FF ⁶		73.7°–54.4°
S35 ⁷		54.3°–38.7°
APS-C ⁸		52.6°–37.4°
Barcode No.		
	EF mount	0085126 588663
	E-mount	0085126 588670
	PL mount	N/A

²24-35mm T2.2 FF is not available in PL mount.

Key features

Wide focal length coverage

The lineup covers everything from wide angle to telephoto. Produce an entire work with SIGMA lenses alone.

Compatibility

Compatibility has been confirmed with each brand of cinema camera.

Lenses for both S35 and full-frame

The High Speed Zoom Line is compatible with Super-35, the image size standard used by typical digital cinema cameras, while the FF High Speed Prime Line and FF Zoom Line are compatible with a full-frame image circle.

Strong high-speed lens lineup

T1.5 or T2 is available in FF High Speed Prime Line, while T2 throughout the zoom range is available in High Speed Zoom Line. These options enable cinematographers to shoot with a wide range of expressive purposes.

Inspecting each and every lens

There are three requirements for outstanding lenses: fine design, precise manufacturing and inspection that ensures compliance with all specifications. SIGMA lenses are born of outstanding design concepts and excellent manufacturing technology, but they are not complete until they undergo their uncompromising lens performance evaluation. SIGMA has developed their own A1 proprietary Modulation Transfer Function (MTF) measuring system using 46-megapixel Foveon direct image sensors. Even previously undetectable high-frequency details are now within the scope of their quality control inspections. Ultra-high-resolution sensors ensure high-performance shooting.

6K-8K class resolution

The lineup features the same optical system that delivers 50-megapixel or higher resolution in still photography. These lenses are therefore ready for higher resolution shooting, and are ideal for chroma keying as well.

Minimization of flare and ghosting

Computer-based ray tracing has been used from the design stage onward to minimize flare and ghosting and enhance contrast in backlit conditions. Ghosting has also been checked at every prototype stage, with its causes identified, assessed, and eliminated.

Sharpness combined with outstanding bokeh effect

To fulfill the high demands for image quality in still photography, SIGMA has solved a wide range of issues. The benefit of these efforts can now be enjoyed in cine lenses as well.

Color balance standardized across the lineup

All of the lenses in the lineup are designed to comply with SIGMA's CCI standard. Standardized color balance makes color correction a snap.

Mount Conversion Service

Seeing lenses as valuable assets, SIGMA now makes the Mount Conversion Service available for its new cine lenses. Successfully implemented for their still photography camera lenses, this service allows users to convert their lenses to and from EF and E-mounts (charges apply). If the camera system changes, it is possible to simply convert the mount system to continue using the high-performance SIGMA lenses.

*The Mount Conversion Service is not available for PL mount lenses

Robust accessory selection

The USB DOCK allows the user to connect the lens to a computer and update firmware, while the MOUNT CONVERTER MC-11 allows users to enjoy the high performance of SIGMA's Canon EF mount interchangeable lenses with the Sony E-mount camera body. These and other accessories further enhance the convenience and ease of use of the new lens lineup.

Lightweight and compact

Leveraging the high-precision, high-efficiency mass production technologies developed for its still camera lenses, SIGMA has made extremely lightweight and compact cine lenses a reality. Featuring all functions essential to cinematography, these lenses keep weight and size to a minimum, while their specification is optimized for enhanced durability. The end result is a combination of performance and compact design at the highest level.

Dust-proof and splash-proof construction

The lineup features the same dust-proof and splash-proof construction as the SIGMA 150-600mm F5-6.3 DG OS HSM | Sports. With each ring and mount specially sealed to prevent water and dust from entering, this lens is ready for use in tough conditions. The unusually robust specification of the lineup allows the user to concentrate on shooting while significantly reducing the burden of maintenance.

100% metal body

The body is made completely of metal to stand up to tough professional use over the long term.

Luminous paint for enhanced visibility

The specification, graduation baseline, and lens change indications all feature luminous paint to aid in changing the lens in the dark and other tasks. Moreover, new FULLY LUMINOUS versions of the lenses feature the above plus rings whose numbers and graduations are finished with luminous paint.

Laser engraving for enhanced durability

Information on rings and elsewhere is laser-engraved for use over the long term. In addition, tape may be placed on graduations without fear of stripping away paint when it is removed.

EF mount, E-mount, and PL mount available

The lenses are available in Canon EF mount, which is used on the majority of digital movie cameras, Sony E-mount, which is used on the Sony FS series; and PL mount, which is prevalent on cinema cameras. All lenses in the lineup may also be used on still cameras with the compatible mount for outstanding still camera videography.

*24-35mm T2.2 FF not available with PL mount

Cine-style front lens cap

All lenses come complete with a conventional cine-style front lens cap.

Selectable focus ring with feet or meter graduations

Based on user needs, a focus ring with either feet or meter graduations may be selected. For a small charge, SIGMA can also convert the ring from one type to the other after purchase.

82mm filter size* 1

The filter size is standardized at 82mm, allowing users to use the same size of ND filter on different lenses.

*Certain lens models are not compatible with 82mm filters.

95mm front diameter 2

The front diameter is 95mm, similar to that of other cine lenses and compatible with matte boxes. Compared to lenses in the same class, SIGMA's cine lenses are more lightweight and compact.

180° focus rotational angle 3

At 180°, the rotational angle of the focus ring is more than double that of a still camera lenses, making possible extremely high-precision focusing. SIGMA has also optimized the cam for cine lenses for even easier long distance focusing.

Standardized gear positions 3 4 5

The positions of the gears in each ring are standardized, eliminating the need to adjust the follow focus, motor unit, or accessories even when the lens changes.

0.8M gear pitch 3 4 5

Each lens has a 0.8M gear pitch, which is the standard for cine lenses, ensuring compatibility with existing accessories.

Silent ring stoppers 3 4 5

The stopper of each ring incorporates a damper made of a special resin, resulting in silent operation. While offering a satisfying lock feel, this feature eliminates any metallic sounds, allowing the user to shoot with confidence in a quiet area.

160° zoom rotational angle 4

At 160°, the rotational angle of the zoom ring is more than double that of a still camera lenses, making possible extremely high-precision zooming.

Iris with full manual control 5

Featuring manual control capability, the iris ring offers smooth control without clicks. The T-stop display, which is standard in cine lenses, contributes to high-precision exposures. Just like other high-end cine lenses, the rotational angle of the iris ring is 60°.

Linear iris ring 5

The linear iris ring gives users the same rotational angle per T-stop for direct, intuitive control.

Mount with electronic contacts 6

The mount with electronic contact allows the lens to communicate important lens information to the body (focal length, shooting distance, aperture, etc.).

*This feature is not included on PL mount lenses

Enhanced EF mount* 6

The hole for the stopper pin has been strengthened with a separate part to minimize loosening over time and enhance long-term use.

*Only applicable for Canon EF mount

Dedicated lens support foot 7

Coming as a standard accessory with all lenses in the lineup, the lens support foot helps minimize load on the camera body while enhancing mount stability. The height of the seating surface is designed for compatibility with other accessories. Even though the lens is compact, its robust design offers two different screw holes for this accessory to increase user options.

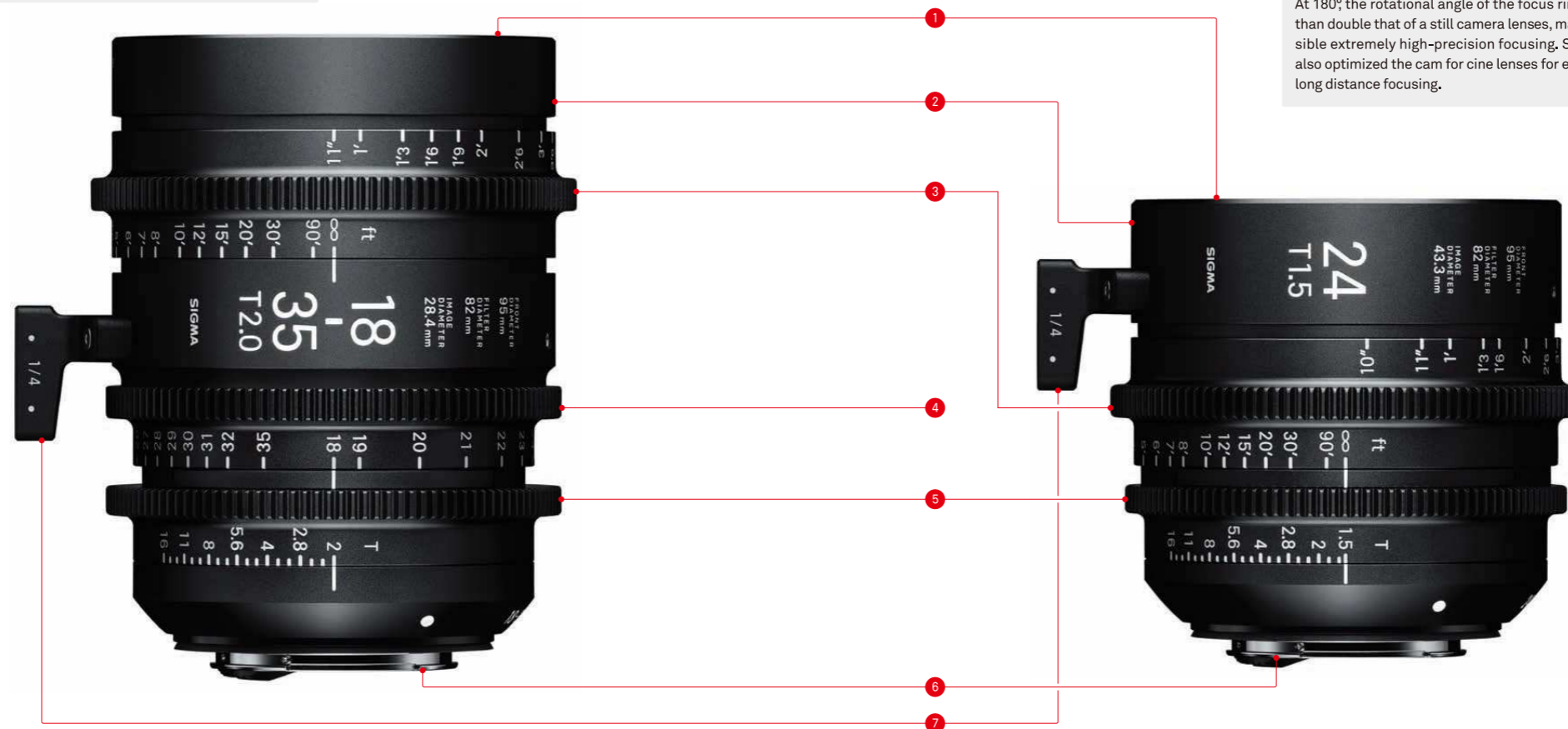



Canon EF Mount



PL Mount



Sony E-Mount

Three mount types available

For compatibility with a wide range of cameras, SIGMA cine lenses are available with the EF mount, E-mount, and PL mount. For a fee, the Mount Conversion Service will convert the mount of the lenses to and from EF and E-mounts. The SIGMA Service Center will check optical performance of the lens and precisely adjust the flange back of the mount to ensure a successful conversion to the new system.

Note 1: 24-35mm T2.2 FF not available with PL mount

Note 2: The mount conversion service is not available for PL mount lenses.

Selectable focus ring with feet or meter graduations

Based on user needs, a focus ring with either feet or meter graduations may be selected. For a fee, SIGMA can also convert the ring from one type to the other after purchase.

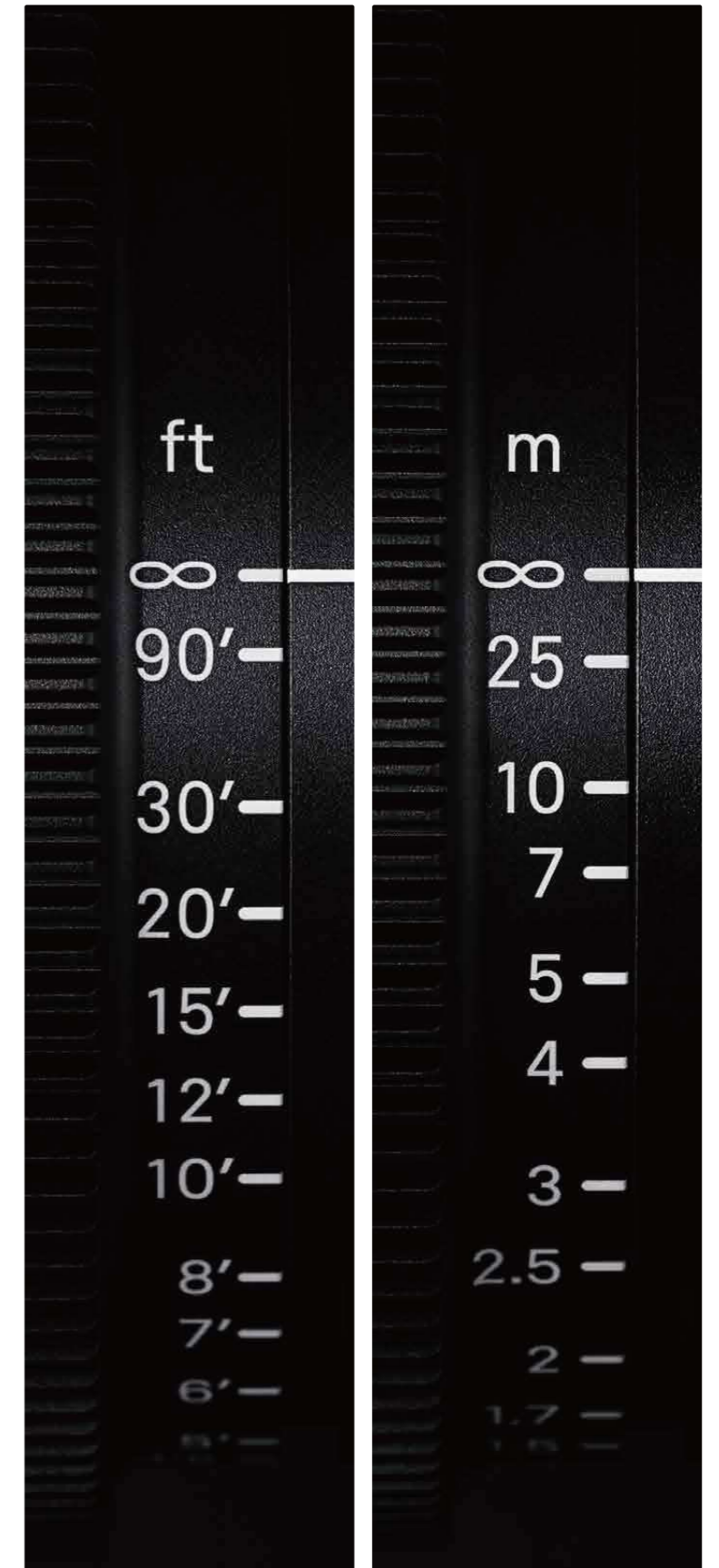

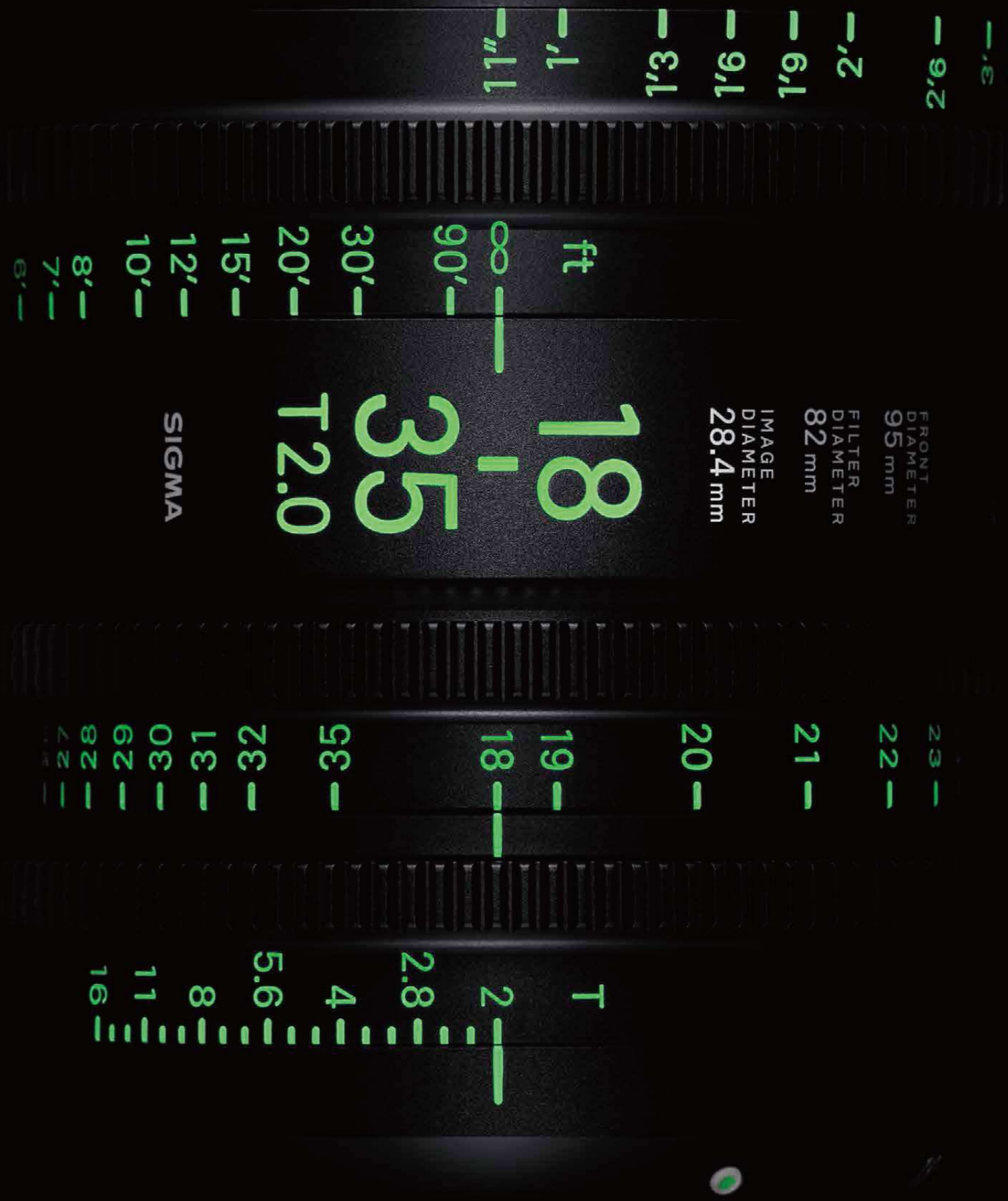

Fully Luminous versions

In these versions of the cine lens lineup, each ring features numbers and graduations finished with luminous paint for easier shooting in the dark. (Both FULLY LUMINOUS and standard versions feature luminous paint on the specification, graduation baseline, and lens change instructions.)

Prime Lenses

These seven prime lenses range from 14mm to 135mm, and all offer T1.5 or T2 brightness. Rivaling a high-end prime set with their outstanding image quality, they also offer full-frame coverage and amazing compactness with a front diameter of only 95mm.

Offering the latest optical design for 8K shooting and more, the FF High Speed Prime Line takes digital cinema cameras to the next level of performance.



14mm T2 FF

Diameter: Actual size



20mm T1.5 FF



24mm T1.5 FF

Diameter: Actual size



35mm T1.5 FF



50mm T1.5 FF

Diameter: Actual size



85mm T1.5 FF



135mm T2 FF

Diameter: Actual size

Prime lens specifications



FF High Speed Prime Line		14mm T2 FF	20mm T1.5 FF	24mm T1.5 FF	35mm T1.5 FF	50mm T1.5 FF	85mm T1.5 FF	135mm T2 FF
Focal Length		14mm	20mm	24mm	35mm	50mm	85mm	135mm
Aperture(T)		T2 to T16	T1.5 to T16	T1.5 to T16	T1.5 to T16	T1.5 to T16	T1.5 to T16	T2 to T16
Number of Diaphragm Blades		9 (Rounded diaphragm)	9 (Rounded diaphragm)	9 (Rounded diaphragm)	9 (Rounded diaphragm)	9 (Rounded diaphragm)	9 (Rounded diaphragm)	9 (Rounded diaphragm)
Close Focus ¹		0.27m / 11"	0.276m / 11"	0.25m / 10"	0.30m / 1'	0.40m / 1'4"	0.85m / 2'10"	0.875m / 2'11"
Image Coverage		FF Φ 43.3mm	FF Φ 43.3mm	FF Φ 43.3mm	FF Φ 43.3mm	FF Φ 43.3mm	FF Φ 43.3mm	FF Φ 43.3mm
Front diameter		95mm	95mm	95mm	95mm	95mm	95mm	95mm
Filter Size		-	-	82mm	82mm	82mm	86mm	82mm
Length	EF mount ²	119.5mm	118mm	95mm	95mm	102mm	134.5mm	126.4mm
	E-mount ³	145.5mm	144mm	121mm	121mm	128mm	160.5mm	152.4mm
	PL mount ⁴	111.5mm	110mm	87mm	87mm	94mm	126.5mm	118.4mm
Weight ⁵	EF mount	1430g	1335g	1125g	1135g	1295g	1475g	1565g
	E-mount	1485g	1395g	1185g	1165g	1355g	1535g	1630g
	PL mount	1345g	1240g	1030g	1035g	1210g	1380g	1495g
FF ⁶		104.3°	84.0°	73.7°	54.4°	39.6°	23.9°	15.2°
S35 ⁷		82.6°	63.2°	54.3°	38.7°	27.6°	16.5°	10.4°
APS-C ⁸		80.5°	61.3°	52.6°	37.4°	26.7°	15.9°	10.0°
Barcode No.	EF mount	TBD	0085126 412661	0085126 401665	0085126 340667	0085126 311667	0085126 321666	TBD
	E-mount	TBD	0085126 412678	0085126 401672	0085126 340674	0085126 311674	0085126 321673	TBD
	PL mount	TBD	0085126 412685	0085126 401689	0085126 340681	0085126 311681	0085126 321680	TBD

¹ Close focus distance is measured from the image plane ² Front to EF mount flange ³ Front to E-mount flange ⁴ Front to PL mount flange ⁵ Without lens support foot ⁶ Horizontal angle of view for a full-frame camera aperture (aspect ratio 1:1.5, dimensions 36mm×24mm / 1.42"× 0.94") ⁷ Horizontal angle of view for a super 35 digital cinema camera aperture (aspect ratio 1:1.8, dimensions 24.6mm×13.8mm / 0.97"× 0.54") ⁸ Horizontal angle of view for an APS-C camera aperture (aspect ratio 1:1.5, dimensions 23.7mm×15.7mm / 0.93"× 0.62") The specifications are subject to change without a notice.



Where creativity begins — but never ends.

Expertise, skill, experience, and passion: this is the incubator and storehouse of them all. The birthplace of products and services, vision and pride. It is the body of the company—but also its mind. In the Aizu factory, their company history and local culture come together in the form of inimitable craftsmanship.



Born of true craftsmanship.
Producing everything in Aizu for
“Made in Japan” quality.

All SIGMA's manufacturing – right down to molds and parts – with a few exceptions, are carried out under a single integrated production system, entirely in Japan. They are now one of the very few manufacturers whose products are solely “made in Japan”. Their products are somehow imbued with the essence of their homeland, blessed as it is with clean air and water, and focused, hard-working people. SIGMA is proud of the authentic quality of their products, born of a marriage between highly attuned expertise and intelligent, advanced technology. Their sophisticated products have satisfied professionals and lovers of photography all over the world, because their manufacturing is based on genuine craftsmanship, underpinned by the passion and pride of their experts.





Genuine

To produce their world-class products, SIGMA pour in all of their technology and passion. They leverage the power of ideas thought of by no one else and experience possessed by no other company. Their goal is always to offer tools that support the fun of photography and the joy of expression. Informed by these principles, the products and services they create are their identity. With their eye on the essence of things, they pursue the genuine to be the genuine. They invite you to take their products in your hands and see with your own eyes.



